

Product Change Notification

Overview: Please be advised that the following is notice of change to Fire Research Focus and Optimum model 200 recessed mount lampheads.

Products Affected: All 200 model lampheads.

Focus series:

FCA200-D15, FCA200-D30

FCA200-H30

FCA200-S30, FCA200-S50, FCA200-S72, FCA200-S75

FCA200-M10, FCA200-M12, FCA200-M15

Optimum series:

OPA200-S30, OPA200-S50, OPA200-S72, OPA200-S75

OPA200-M10, OPA200-M12, OPA200-M15

OPA200-R90

Change Description: The top, center mounting screw for this recessed fixture is being eliminated. There will no longer be a hole in the casting at this position.

There are no functional differences. The mounting cutout and the other five screw holes remain the same. This change will be in effect by July 2010.

Reason For Change: Provides for easier installation of the recessed mount casting.

Replacement Product: The fixture has the same form, fit, and function and will be a direct replacement minus the top center screw. The existing screw hole in the apparatus should be sealed.

References: The following drawing is available to show the mounting holes and dimensions: DWG. NO. PCN1006-01 dated 02JUN10. For detailed engineering drawings contact FRC.

Response: No response to this notification is required. Requests for additional information should be directed to an FRC sales representative at 1.800.645.0074.

TOP MOUNTING HOLE HAS BEEN REMOVED

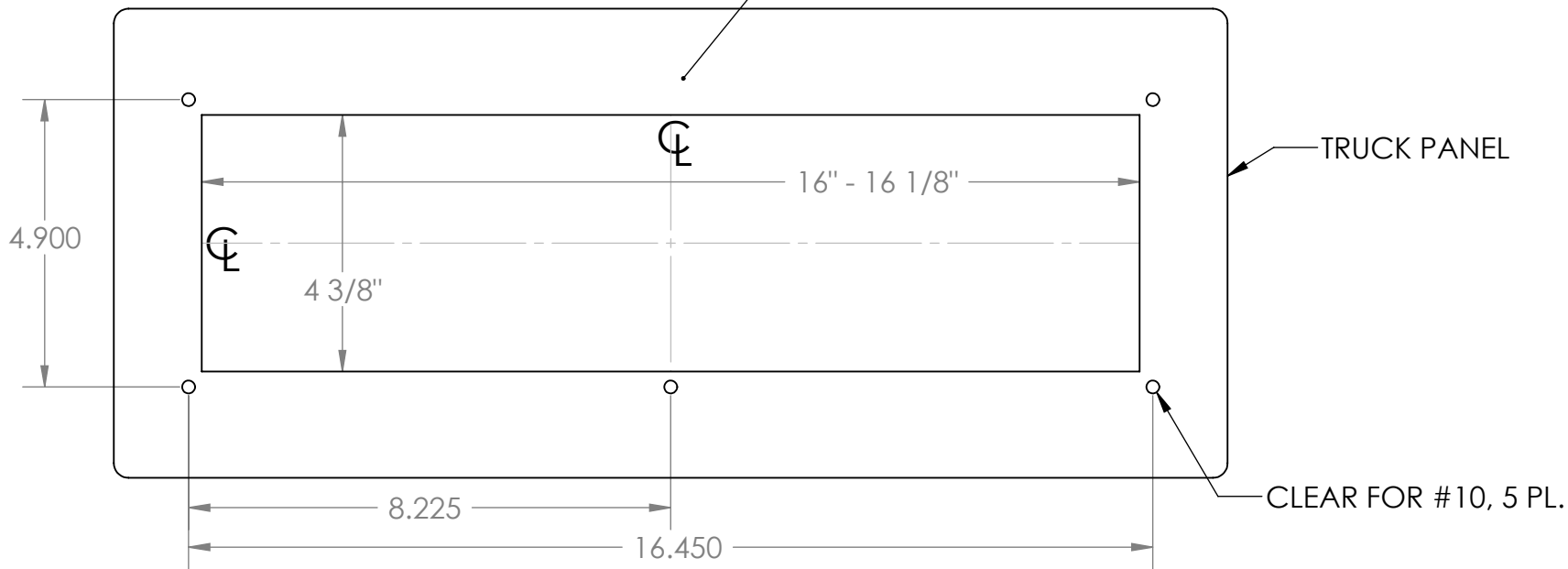

NOTE:
FOR ALL
FOCUS
AND
OPTIMUM
M SERIES
(D30 AND
R90)

TOP MOUNTING HOLE HAS BEEN REMOVED

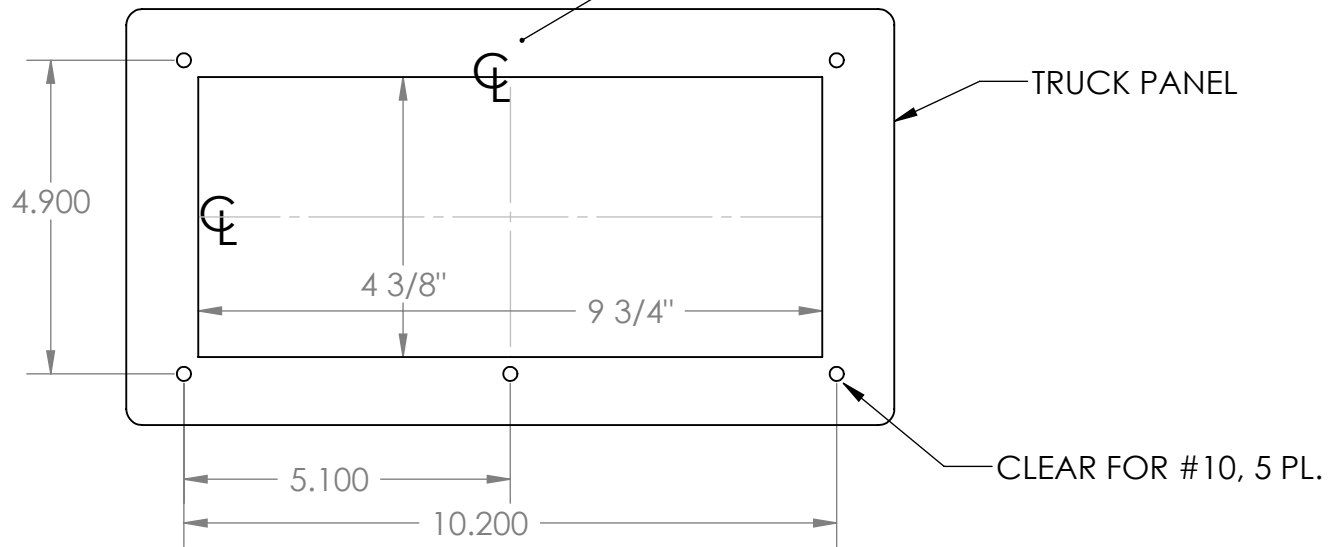

NOTE:
FOR ALL
FOCUS
AND
OPTIMUM
S SERIES
(H30 AND
D15)

DIMENSIONS ARE IN INCHES		DRAWN: Paul G	DATE: 6/2/2010	TITLE: Focus and Optimum Flushmnt Cutouts	
COMMENTS:				SIZE: A	DWG. NO. PCN1006-01
TOLERANCES:		MATERIAL:		SCALE: 1:3	
ANGULAR: MACH ± .1		FINISH:		FRC	SHEET: 1 OF 1
2 PLACE DECIMAL ± .015					REV:
3 PLACE DECIMAL ± .005					